

558D SOURCE GUIDE

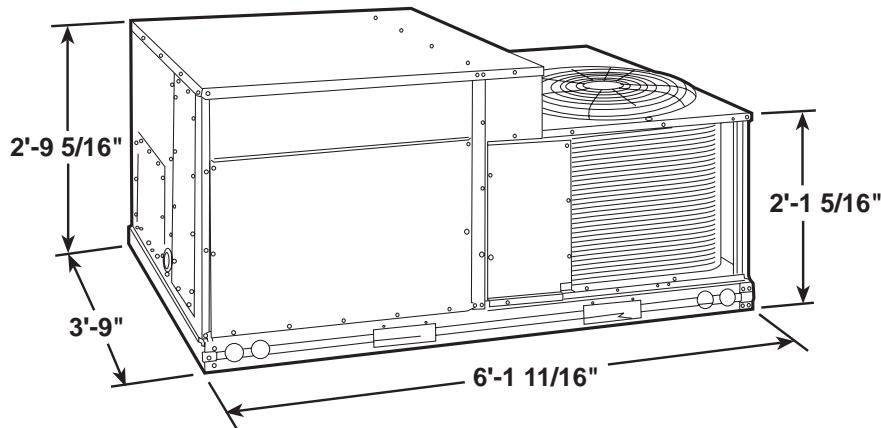

558D

**Standard Efficiency
Electric/Electric Rooftop Units
3 - 12.5 Tons**



558D036-072

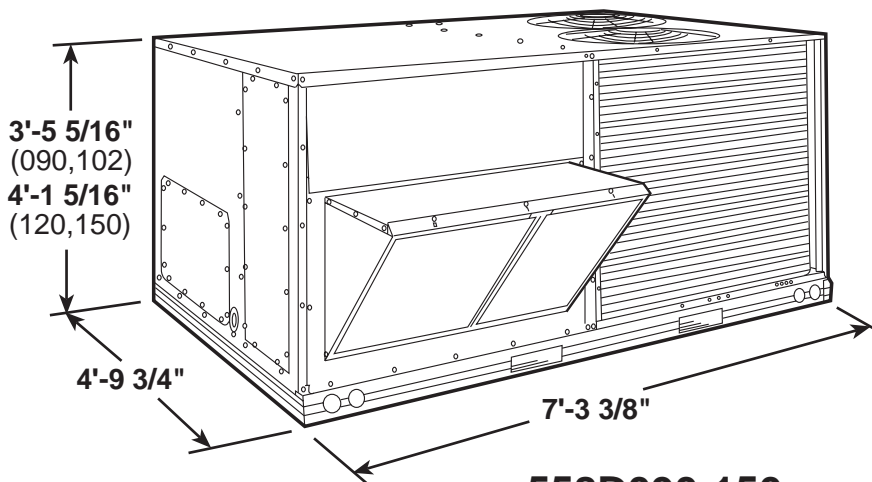

558D090-150

Features

- Commercial Workhorse Providing 3-12.5 Tons at Standard Efficiency
- Accessory Electric Heaters and Single Point Wiring Kits Available
- Superior Access to Filters, Drain Pan, Indoor and Outdoor Coils, and Compressors for Quick Service
- Easily Converted from Vertical to Horizontal Supply and Return
- Only Two Roof Curbs Required for 3-12.5 Tons
- Sloped, Composite Condensate Drain Pan
- Full Perimeter Base Rails with Built in Rigging Capability
- Low Ambient Operation to 25°F Standard, -20°F with Accessory
- Weather Resistant Cabinet is Coated with Prepainted Enamel Finish and G60 Galvanized Base
- Full Line of Commercial Accessories Available
- Unequalized Line of Factory Installed Options:
 - High Static Motors
 - Manual Air Economizer
 - Refrigerant Controls Upgrade
 - Copper or Technicoat Coils
- 1-Year Product Warranty
- 5-Year Compressor Warranty

**SIZING AND
SELECTION CHART**

CAPACITY RATINGS

MODEL	NOM. TONS	ARI* COOLING PERFORMANCE			NOM. CFM	APPROX. SHIPPING WEIGHT (lbs)	SOUND (bels)
		BTUH	SEER**	EER			
558D036	3	35,000	10	-	1200	365	8.2
558D048	4	47,000	10	-	1600	375	8.2
558D060	5	57,500	10	-	2000	395	8.2
558D072	6	70,000	-	8.9	2100	470	8.4
558D090	7.5	86,000	-	8.9	2800	755	8.6
558D102	8.5	98,000	-	9	3000	760	8.6
558D120	10	117,000	-	9	4000	915	8.8
558D150	12.5	142,000	-	9	4500	930	8.8

* Air-Conditioning & Refrigerant Institute.

** SEER Rates are with Alternate Motor.





residential/ hvac commercial



[residential hvac](#) / [commercial hvac](#) / [about us](#) / [what's new](#)

Welcome to Barker Mechanical Services Inc. Our HVAC firm has been serving the San Francisco Bay Area for over 50 years and provides residential and commercial air conditioning and heating installation, maintenance and repair.

We look forward to serving your heating & cooling needs!

Joe Barker, President

6800 Sierra Court Suite L
Dublin, CA 94568

925-560-0280 phone
925-560-0288 fax

info@barkermech.com email