

657A SOURCE GUIDE

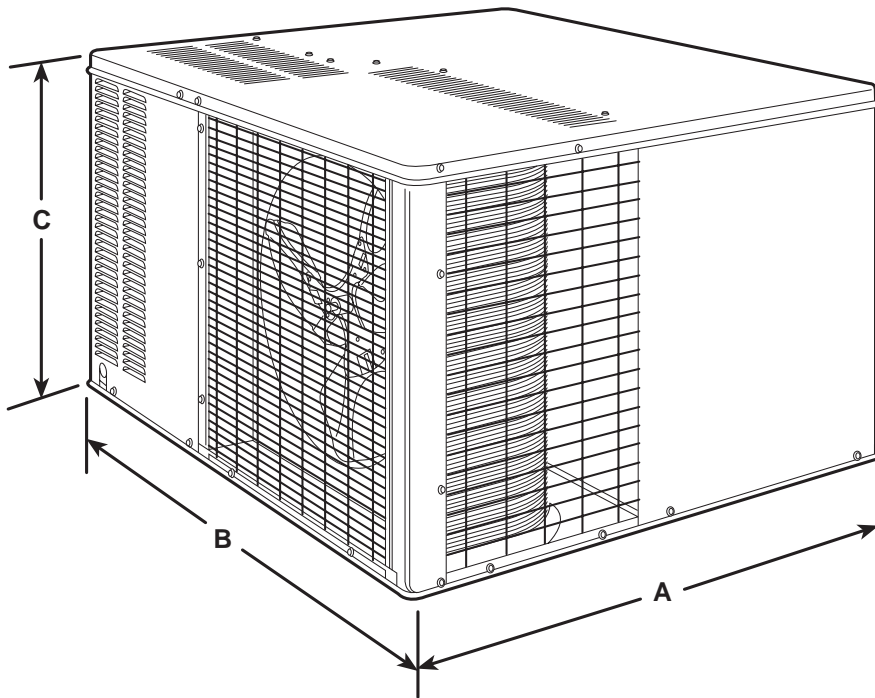

657A High Efficiency Heat Pump Packaged Product 2.0 - 5.0 Tons



Base Unit Dimensions (Without Base Rail)

MODEL NUMBERS	A	B	C
657A024-036	36.8	43.7	28.1
657A042-060	36.8	43.7	34.1

All Dimensions in inches

Features

- High-Efficiency up to 12 SEER
- Reliable Compressor Operation Down to Low Ambient Temperatures During the Heating Season
- Time/Temperature Defrost System
- Loss of Charge Switch
- Scroll Compressor
- Single Point Electric Connection Box with Electric Heat
- Quiet Operation Sound Levels as Low as 7.8 Bels
- Field-Installed Supplemental Electric Heat Packages Mount Inside the Unit Blower Compartment
- Optional Commercial Grade Base Rails

**SIZING AND
SELECTION CHART**

HEAT PUMP

MODEL NUMBER	NOMINAL TONS	STANDARD CFM	OPERATING WEIGHT (lbs)	NET COOLING	
				BTUH	SEER
657A024	2.0	800	309	23,400	12.0
657A030	2.5	1000	340	28,600	12.0
657A036	3.0	1200	343	35,000	12.0
657A042	3.5	1400	368	41,500	12.0
657A048	4.0	1600	411	47,500	12.0
657A060	5.0	1800	425	57,000	11.0

MODEL NUMBER	HEATING (HIGH TEMP) AT 47 F			HEATING (LOW TEMP) AT 17 F		SOUND LEVELS (Bels)
	BTUH	COP	HSPF	BTUH	COP	
657A024	23,800	3.2	6.9	12,400	1.8	7.8
657A030	28,200	3.2	7.1	15,400	1.9	7.8
657A036	34,400	3.4	7.1	18,000	1.9	8.0
657A042	40,000	3.3	7.0	31,000	1.9	8.0
657A048	44,000	3.5	7.0	23,600	2.0	8.2
657A060	57,000	3.5	7.2	31,800	2.0	8.2

NOTES: Operating weight does not include base rails.

ROOF CURB DIMENSIONS — 657A

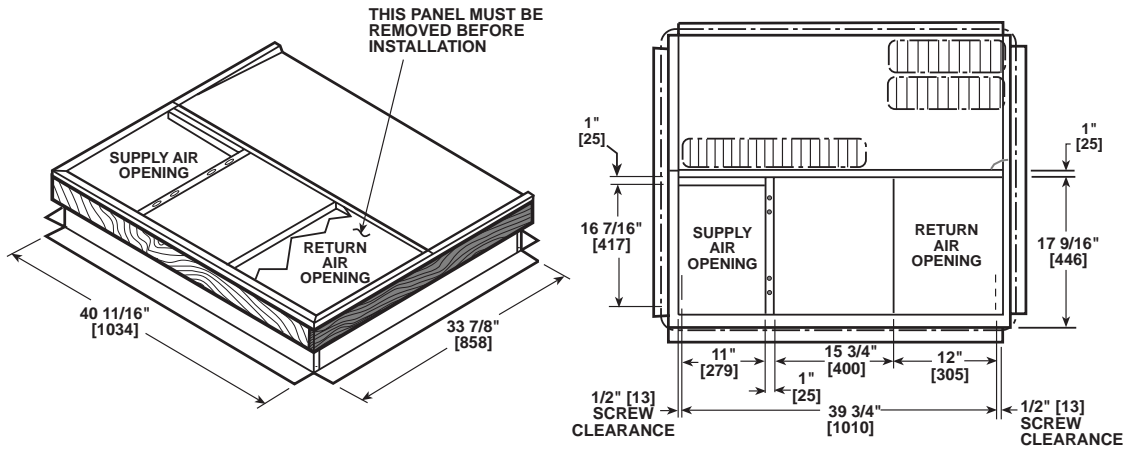



residential/ hvac commercial



[residential hvac](#) / [commercial hvac](#) / [about us](#) / [what's new](#)

Welcome to Barker Mechanical Services Inc. Our HVAC firm has been serving the San Francisco Bay Area for over 50 years and provides residential and commercial air conditioning and heating installation, maintenance and repair.

We look forward to serving your heating & cooling needs!

Joe Barker, President

6800 Sierra Court Suite L
Dublin, CA 94568

925-560-0280 phone
925-560-0288 fax

info@barkermech.com email