

658A SOURCE GUIDE

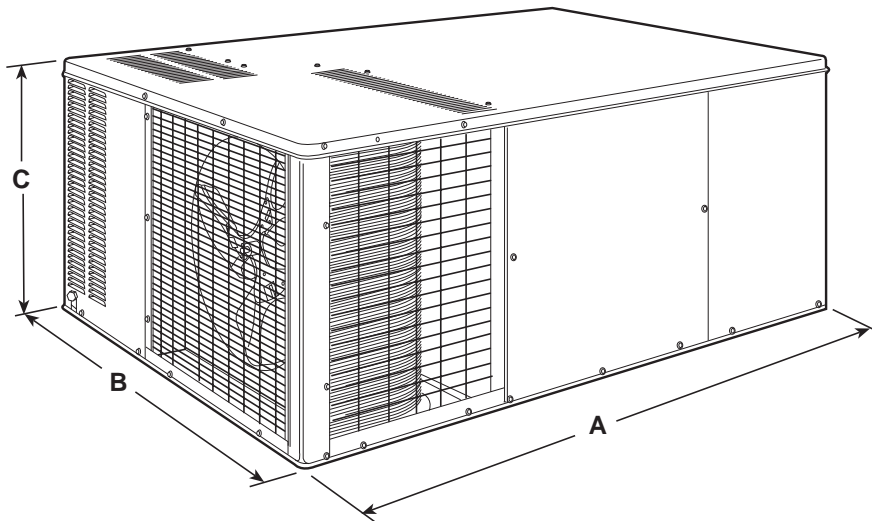

658A High Efficiency Dual Fuel Heat Pump 2.5 - 5.0 Tons



Features

- Heat Pump with Gas Heating Capability to Maximize Heating Efficiency
- Convertible Airflow for Down or Side Supply Applications
- Quiet Operation Ratings as Low as 7.8 Bels
- High-Efficiency up to 12 SEER
- Easy Access to all Components
- Low Profile, Compact Cabinet Size
- Weatherized Cabinet is Made of Sturdy Zinc-Coated, Pre-Painted Steel
- Optional Commercial Grade Base Rails

Base Unit Dimensions (Without Base Rail)

MODEL NUMBERS	A	B	C
658A030-036	49.6	43.7	28.1
658A048-060	49.6	43.7	34.1

All dimensions in inches

**SIZING AND
SELECTION CHART**

658A DUAL FUEL SIZING AND SELECTION CHART

MODEL NUMBER	NOMINAL TONS	STANDARD CFM	SOUND LEVELS (Bels)	OPERATING WEIGHT (lbs)	NET COOLING	
					BTUH	SEER
658A030040	2.5	1000	7.8	346	28,600	12.0
658A030060	2.5	1000	7.8	358	28,600	12.0
658A036060	3.0	1200	8.0	376	35,000	12.0
658A036080	3.0	1200	8.0	376	35,000	12.0
658A048080	4.0	1600	8.2	432	47,500	12.0
658A048100	4.0	1600	8.2	432	47,500	12.0
658A060080	5.0	1800	8.2	463	57,000	11.0
658A060100	5.0	1800	8.2	463	57,000	11.0

GAS HEAT PERFORMANCE			HEAT PUMP PERFORMANCE				
MODEL NUMBER	HEATING INPUT (Btuh)	AFUE %	HEATING (HIGH TEMP) AT 47 F			HEATING (LOW TEMP) AT 17 F	
			BTUH	COP	HSPF	BTUH	COP
658A030040	40,000	81	28,200	3.2	7.1	15,400	1.9
658A030060	56,000	81	28,200	3.2	7.1	15,400	1.9
658A036060	56,000	81	34,400	3.4	7.1	18,000	1.9
658A036080	80,000	81	34,400	3.4	7.1	18,000	1.9
658A048080	80,000	81	44,000	3.5	7.0	23,600	2.0
658A048100	95,000	81	44,000	3.5	7.0	23,600	2.0
658A060080	80,000	81	57,000	3.5	7.2	31,800	2.0
658A060100	95,000	81	57,000	3.5	7.2	31,800	2.0

NOTES: Operating weight does not include base rail

ROOF CURB DIMENSIONS — 658A

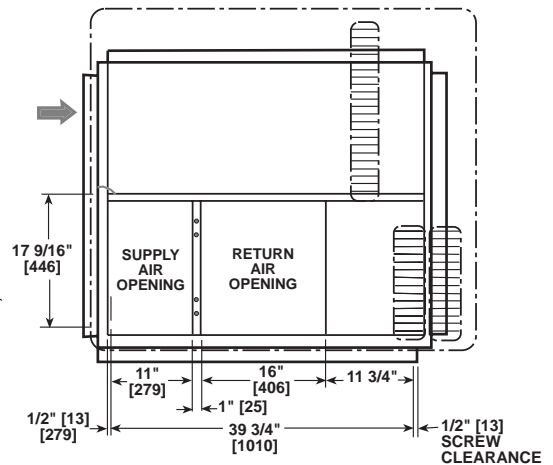
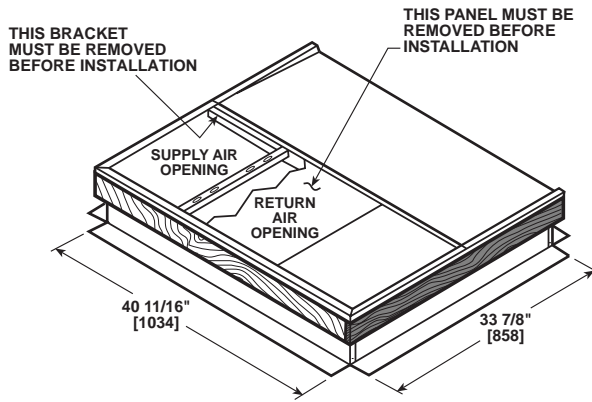



residential/ hvac commercial



[residential hvac](#) / [commercial hvac](#) / [about us](#) / [what's new](#)

Welcome to Barker Mechanical Services Inc. Our HVAC firm has been serving the San Francisco Bay Area for over 50 years and provides residential and commercial air conditioning and heating installation, maintenance and repair.

We look forward to serving your heating & cooling needs!

Joe Barker, President

6800 Sierra Court Suite L
Dublin, CA 94568

925-560-0280 phone
925-560-0288 fax

info@barkermech.com email